

# DL

# DL-B

Slim, compact gauges

- Magnetic principle
- Excellent resistance to workshop conditions (DL310B: IP64). Resistant to dust and vibrations.
- Compact size ideal for designing into machines.
- A/B phase output by open collector
- Measuring range: 10 mm / 0.39" and 30 mm / 1.18"

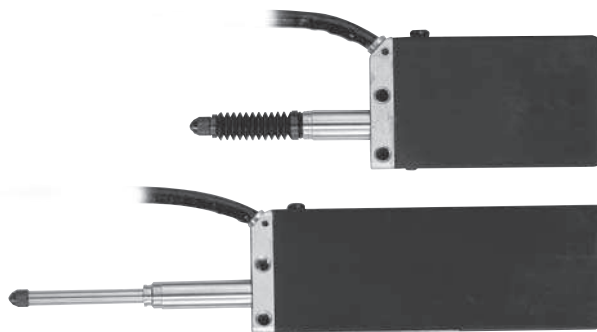
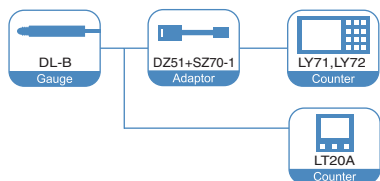

Digital Gauge

## Dimensions

DL310B

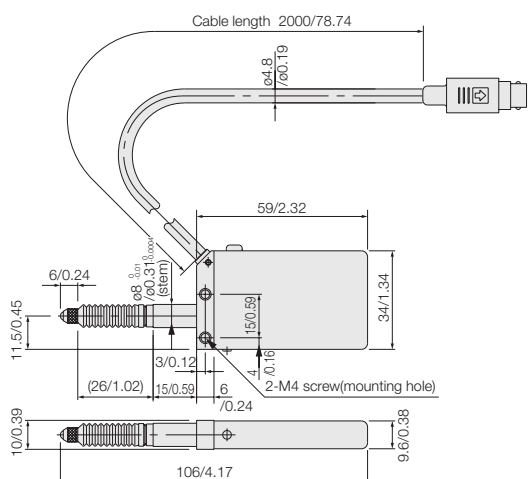

DL330B

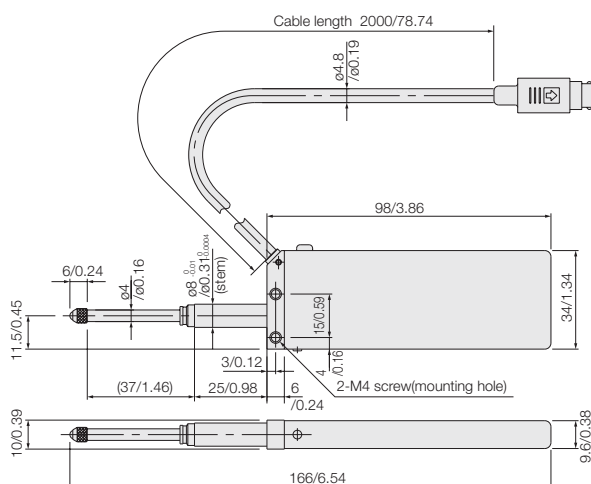

Unit : mm/inch

## Specifications

Model	DL310B	DL330B
Measuring range	10 mm / 0.39"	30 mm / 1.18"
Resolution		10 $\mu$ m
Accuracy (at 20 °C / 68 °F)		10 $\mu$ m
Measuring force		1.5 N or less
Output signal	A/B phase by NPN open collector (12 VDC, 10 mA or less)	
Maximum response speed*1	120 m / min	
Protective design grade	Equivalent to IP 64	—
Mounting stem diameter	$\phi 8 \frac{0.01}{0.0004}$ mm / $\phi 0.31 \frac{0.0004}{0.0004}$ "	
Operating temperature	0 °C to 50 °C / 32 °F to 122 °F	
Storage temperature	-10 °C to 60 °C / 14 °F to 140 °F	
Power supply	5 VDC $\pm$ 5%	
Power consumption	0.2 W	
Cable length	2 m / 6.56**2	
Feeler	Feeler tipped with 3 mm dia. carbide ball with M2.5 x 0.45 screw on fitting end (DZ123)	
Mass (excl. cable unit)	60 g / 2.12 oz	90 g / 3.17 oz
Vacuum pressure for Air lifter	6.0 x 10 <sup>4</sup> to 7.5 x 10 <sup>4</sup> Pa	—

\*1: Max. response speed of the electrical circuit.

\*2: Please consult our sales for more than 2m.

\*Consult us when using DL310B/ 330B with the probe facing upward.